

Lubricate all seals with clean hydraulic fluid prior to assembly.
Do Not Use Silicone Based Lubricants.

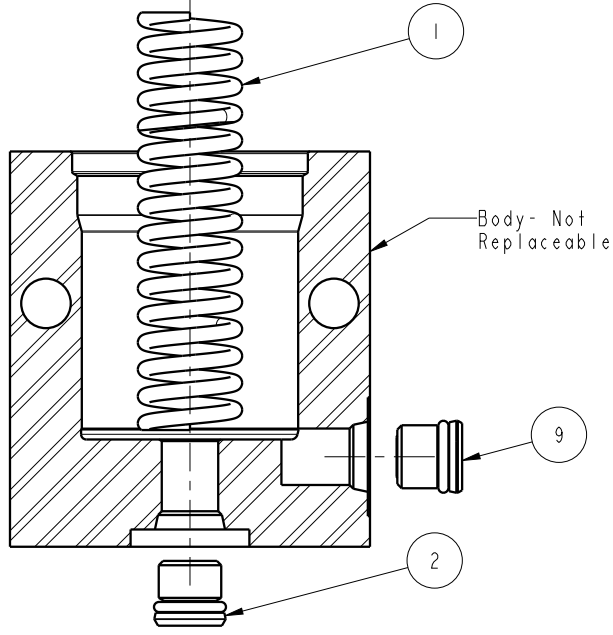
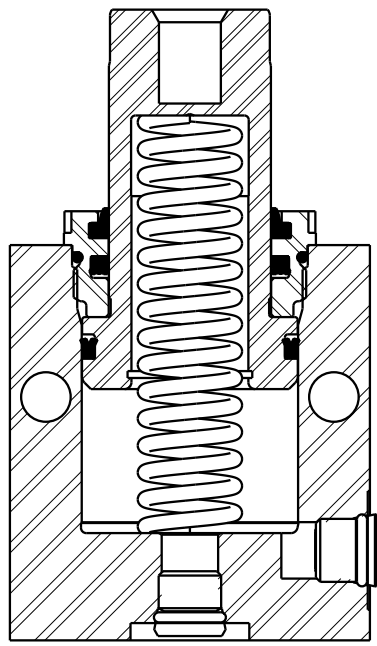
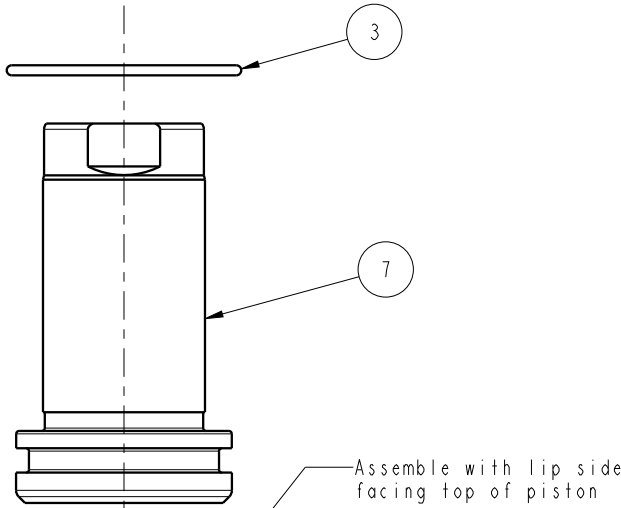
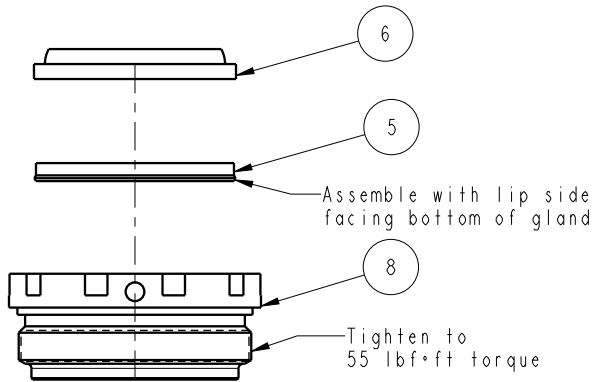

Standard Seal Kit 60-2011-15	Fluorocarbon Seal Kit 6V-2011-15	Spring Kit 61-2011-15
39-0110-28	39-0120-15	23-3130-19
39-0110-48	39-0120-07	
39-0010-13	39-0120-14	
39-0500-20	39-0500-20	

No.	QTY	PART No.	DESCRIPTION
9	1	92090001	ASSY, BREATHER, SAE #4
8	1	82031501	GLAND, CYL, 8800 & 39.9 KN
7	1	82011505	PISTON, CYL, 8800, 1 STRK
6	1	39050020	WIPER, SNAP-IN, (1-1/8)
5	1	39011048	SEAL, LL, (1-1/8 X 1/8 X 1/8 X 1-3/8)
4	1	39011028	SEAL, BEVEL, 1-5/16 X 3/32 X 1-1/2
3	1	39001013	O-RING, (-029)
2	1	30601144	PLUG, SOCH, SAE 4
1	1	23313019	SPRING, COMPRESSION

PARTS LIST



VEKTEK, INC.
1334 E. SIXTH AVE. P.O. BOX 625
EMPORIA, KS. 66801 U.S.A.

Model Number
25-1115-11
25-1115-11F

ASSY, CYL, PULL, BB, 3800, 1 STRK

PARTS LIST

SIZE
A

PL2131

REV
G

FORM FEG035_PL_ASIZE, REV. B

G	5499	RELEASE	NPETERS	9/23/24
REV	IN ACCORDANCE WITH ECN	EFFECTIVE DATE	REVISED BY	DATE
DRW BY:	BUSH	DRAWING STATUS: Released		
DATE:	12-10-96	PRODUCTION APPROVED FOR RELEASED STATUS ONLY		

SHEET 1 OF 1